



SNOW BRACKET™ LUDOWICI® HIGH - APEX

DESCRIPTION

- Designed for Ludowici® S-Tile, and Pan and Cover Tile
- Can be used with Ludowici® Spanish, Italian Pan, and Palm Beach tiles
- Formed to correspond to tile's length
- Bracket fastens to roof sheathing material
- Superior strength
- Can be powder coated to match roofing material color
- Overall dimensions: 2.25"W X 3"H X 20.74"L

MATERIALS

- Zinc Coated Steel: 16 ga (ASTM A653)
- Copper: 48 oz (ASTM B152)
- Stainless Steel: 16 ga (ASTM A240)

COLORS/FINISHES

- Zinc Plated
- Powder coating available in many colors visit <http://trasnowandsun.com/color-chart/> to see color chart

NOTE: Due to specific job conditions, TRA Snow and Sun will only warranty a snow retention system/layout that has been designed by TRA Snow and Sun.



FOR HIGH PROFILE TILES

**USED ON: ITALIAN PAN, PALM BEACH,
AND SPANISH TILE**

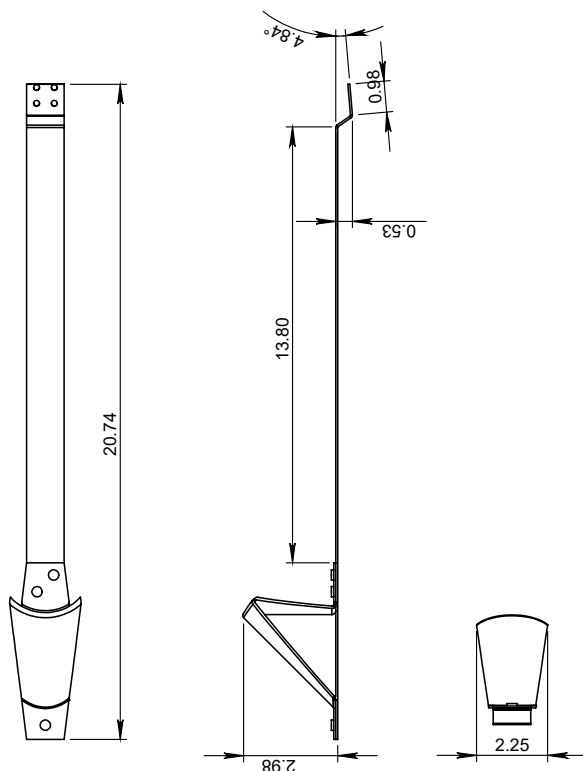

DIMENSIONS
DO NOT SCALE

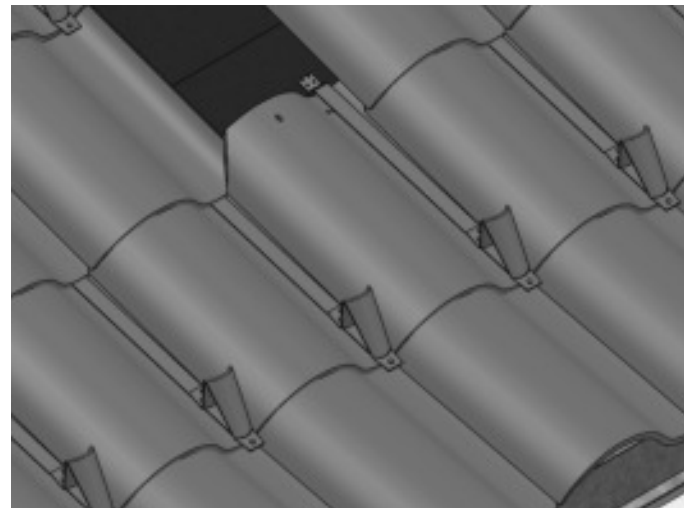

INSTALLATION:

BRACKET IS INSTALLED WITH FOUR 2" ROOFING NAILS DIRECTLY INTO SHEATHING WITH TRIANGULAR END OF BRACKET AT EAVE END OF TILE AND UPPER END UNDER TILE IN COURSE ABOVE.

SNOW RETENTION SYSTEMS