



SNOW BRACKET™ J - APEX

DESCRIPTION

- Designed for use with metal/granule tiles which are installed using horizontal battens
- 3/16" screws required
- Can be powder coated to match roofing material color
- Overall dimensions: 13-1/2"L X 1-3/16"W X 3" H

MATERIALS

- Zinc Coated Steel: 16 ga (ASTM A653)
- Copper: 48 oz (ASTM B152)
- Stainless Steel: 16 ga (ASTM A240)

COLORS/FINISHES

- Zinc Plated
- Powder coating available in many colors visit <http://trasnowandsun.com/color-chart/> to see color chart

NOTE: Due to specific job conditions, TRA Snow and Sun will only warranty a snow retention system/layout that has been designed by TRA Snow and Sun.



FOR NEW CONSTRUCTION & RETROFIT

USED ON: METAL/GRANULE TILES WHICH ARE INSTALLED USING HORIZONTAL BATTENS

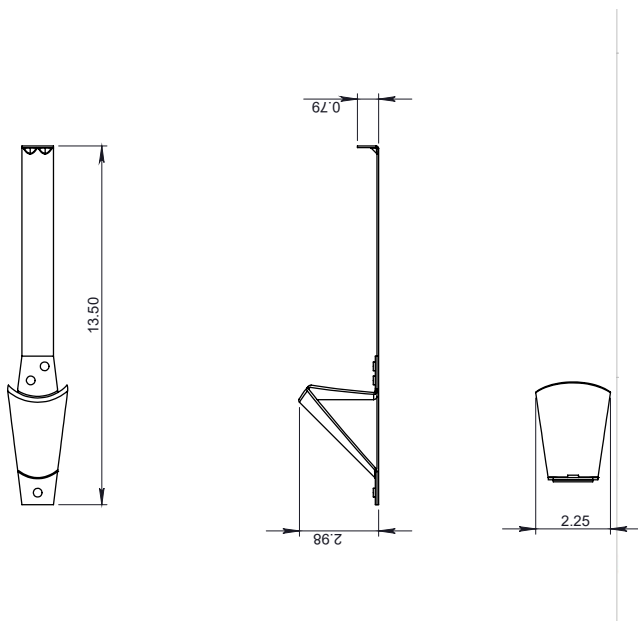

DIMENSIONS
DO NOT SCALE

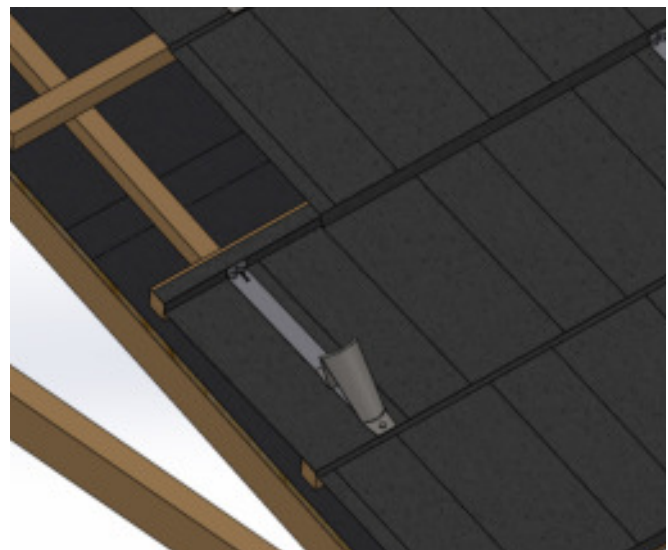

After metal tile has been installed on deck with 2"x2" batten, install the J bracket with the triangular end towards the down hill slope. Install a high quality construction adhesive below the triangular end of the bracket. Then install 3/16" screw into through hole in the snow bracket through hole in metal/granule tile into 2"x2" batten a minimum of 1 1/4".

SNOW RETENTION SYSTEMS