



## SNOW BRACKET™ I (CREST) - APEX

### DESCRIPTION

- Designed for use on corrugated metal roofs
- Bracket tail bent to match panel corrugation
- Installed using (2) #14 fasteners
- Can be powder coated to match roofing material color
- Overall dimensions: 11-9/16" L X 2-1/4" W X 2-61/64" H

### MATERIALS

- Zinc Coated Steel: 16 ga (ASTM A653)
- Copper: 48 oz (ASTM B152)
- Weathering Steel (known as CORTEN®): 16 ga (ASTM A606)
- Stainless Steel: 16 ga (ASTM A240)

### COLORS/FINISHES

- Zinc Plated
- Powder coating available in many colors visit <http://trasnowandsun.com/color-chart/> to see color chart

**NOTE:** Due to specific job conditions, TRA Snow and Sun will only warranty a snow retention system/layout that has been designed by TRA Snow and Sun.



**FOR NEW CONSTRUCTION OR RETROFIT**

**USED ON: CORRUGATED METAL**

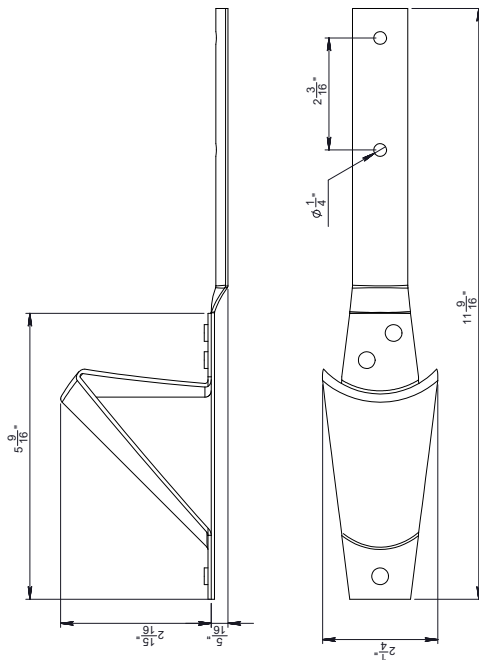

**DIMENSIONS**  
DO NOT SCALE

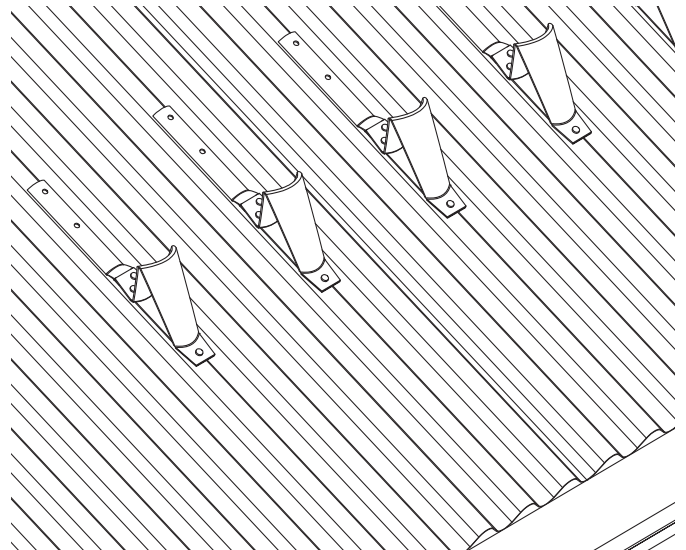

Bracket installed using (2) #14 screws fastened through roof material and sheathing below. Bracket installed with triangular portion of bracket towards roof eave.

**SNOW RETENTION SYSTEMS**