



SNOW BRACKET H - APEX

DESCRIPTION

- Installed using (2) screws that must penetrate the sheathing
- Designed for almost all roof types
- Can be powder coated to match roofing material color
- Overall dimensions: 5.588" L X 2 1/4" W X 3" H

MATERIALS

- Zinc Coated Steel: 16 ga (ASTM A653)
- Copper: 48 oz (ASTM B152)
- Stainless Steel: 16 ga (ASTM A240)

COLORS/FINISHES

- Zinc Plated
- Powder coating available in many colors visit <http://trasnowandsun.com/color-chart/> to see color chart

NOTE: Due to specific job conditions, TRA Snow and Sun will only warranty a snow retention system/layout that has been designed by TRA Snow and Sun.



FOR NEW CONSTRUCTION OR RETROFIT

USED ON: ALMOST ALL ROOF TYPES

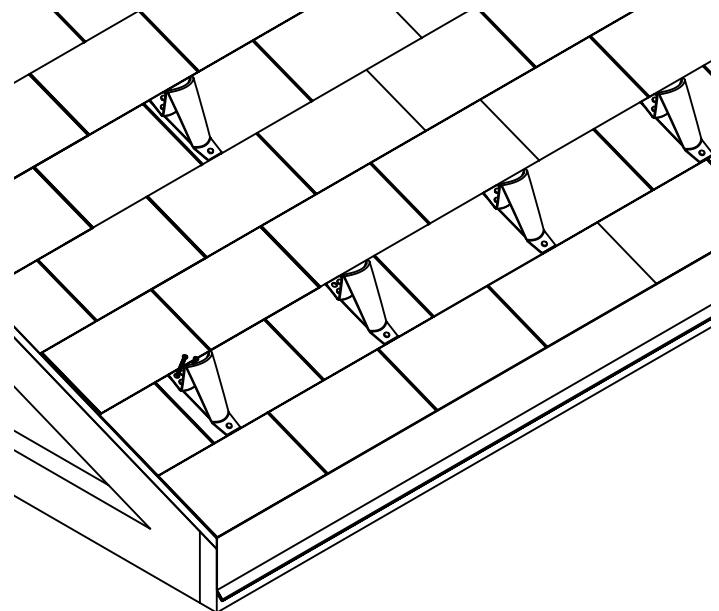
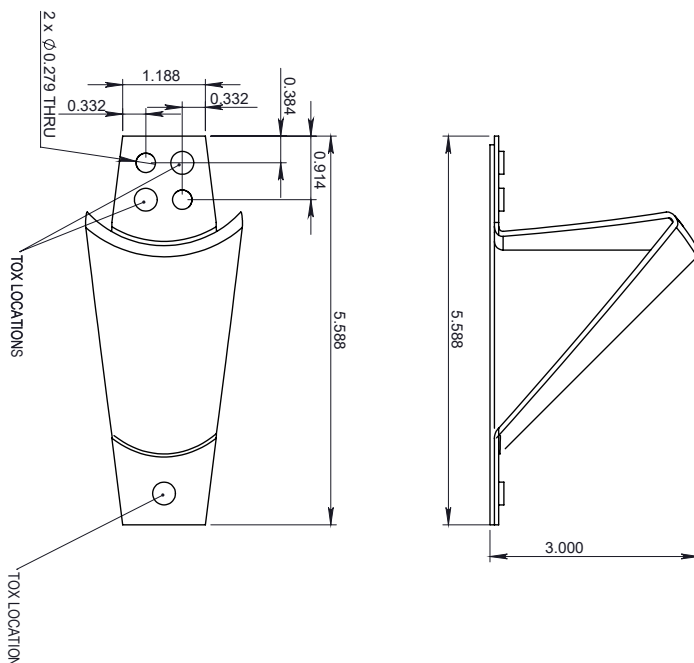

INSTALLATION:
BRACKET IS INSTALLED WITH TWO 2-1/2" SCREWS WITH TRIANGULAR END OF BRACKET AT EAVE END OF ASPHALT SHINGLE.

DIMENSIONS
DO NOT SCALE