



SNOW BRACKET™ F EXTENDED - APEX

DESCRIPTION

- Designed for slate, simulated slate, wood shake and cedar shingles
- Installed using (4) 2" roofing nails or #8 stainless steel screws
- Can be powder coated to match roofing material color
- Overall dimensions: 19.53" L X 1.19" W X 3" H
- Can be manufactured in custom lengths

MATERIALS

- Zinc Coated Steel: 16 ga (ASTM A653)
- Copper: 48 oz (ASTM B152)
- Stainless Steel: 16 ga (ASTM A240)

COLORS/FINISHES

- Zinc Plated
- Powder coating available in many colors visit <http://trasnowandsun.com/color-chart/> to see color chart

NOTE: Due to specific job conditions, TRA Snow and Sun will only warranty a snow retention system/layout that has been designed by TRA Snow and Sun.



FOR NEW CONSTRUCTION

USED ON: CEDAR SHINGLES, WOOD SHAKES, SLATE, AND SIMULATED SLATE

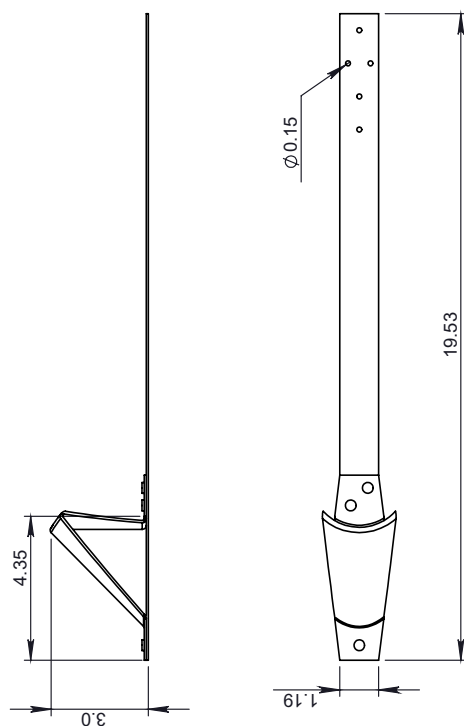

DIMENSIONS
DO NOT SCALE

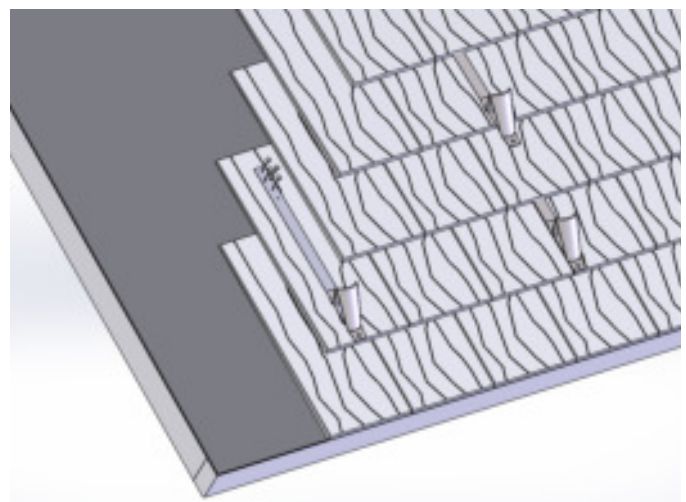

Bracket to be installed using (4) #8 stainless steel screws or roofing nails fastened through roofing material and sheathing below.

SNOW RETENTION SYSTEMS