



SNOW BRACKET™ B CB - CLASSIC

DESCRIPTION

- Designed for use with concrete tiles 15" in length which are installed using counter batten system
- No fasteners required
- Can be powder coated to match roofing material color
- Overall dimensions: 15-3/8"L X 1-3/16"W X 4-3/4" H

MATERIALS

- Zinc Coated Steel: 16 ga (ASTM A653)
- Copper: 48 oz (ASTM B152)
- Stainless Steel: 16 ga (ASTM A240)

COLORS/FINISHES

- Zinc Plated
- Powder coating available in many colors visit <http://trasnowandsun.com/color-chart/> to see color chart

NOTE: Due to specific job conditions, TRA Snow and Sun will only warranty a snow retention system/layout that has been designed by TRA Snow and Sun.



FOR NEW CONSTRUCTION

USED ON: BARTILE, VANDE-HEY AND OTHER SIMILAR TILES WHICH ARE INSTALLED USING A COUNTER BATTEN SYSTEM

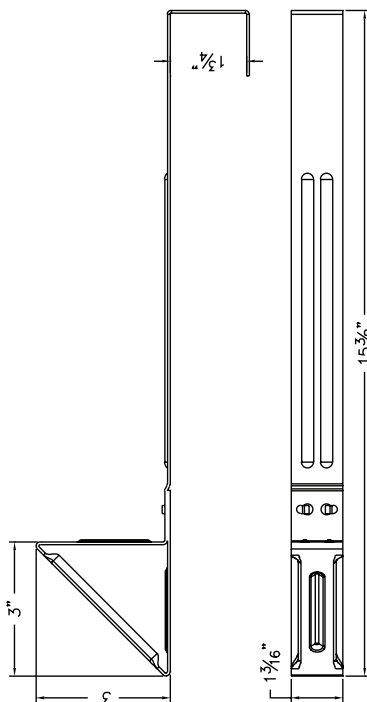

DIMENSIONS
DO NOT SCALE

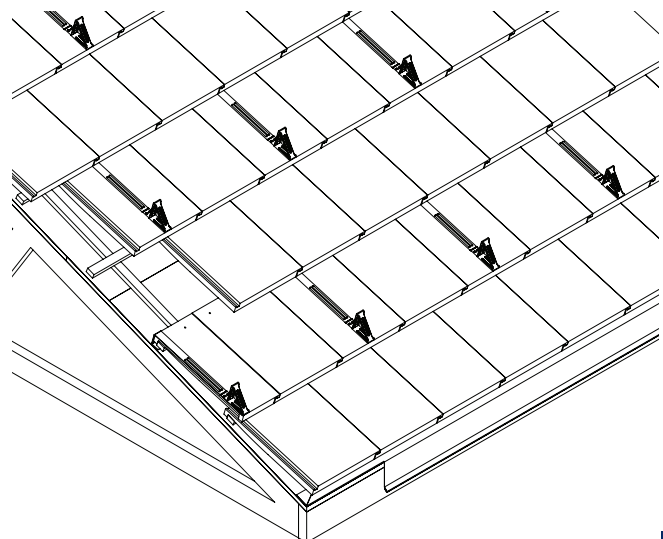

Snow Bracket hooks to upper end of roof tile and counter batten. Bracket is installed with triangular end of bracket at butt end of roof tile and upper end under the course above.

SNOW RETENTION SYSTEMS