



SNOW BRACKET™ B - APEX

DESCRIPTION

- Designed for use with concrete or clay tiles 15" in length which are installed using horizontal battens
- (1) 10 D galvanized nail fastener required and purchased separately
- Can be powder coated to match roofing material color
- Overall dimensions: 14 9/16" L X 2 1/4" W X 3" H

MATERIALS

- Zinc Coated Steel: 16 ga (ASTM A653)
- Copper: 48 oz (ASTM B152)
- Stainless Steel: 16 ga (ASTM A240)

COLORS/FINISHES

- Zinc Plated
- Powder coating available in many colors visit <http://trasnowandsun.com/color-chart/> to see color chart

NOTE: Due to specific job conditions, TRA Snow and Sun will only warranty a snow retention system/layout that has been designed by TRA Snow and Sun.

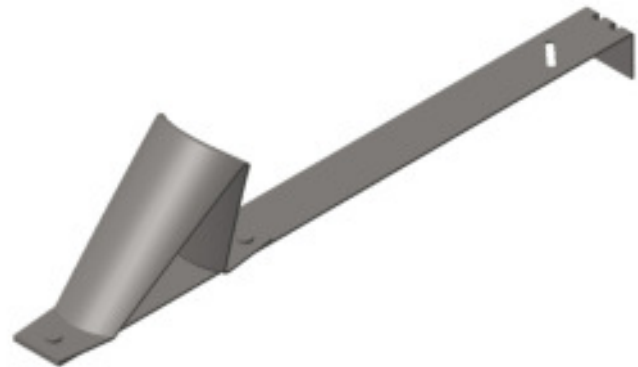

FOR NEW CONSTRUCTION OR RETROFIT

USED ON: BARTILE, VANDE HEY RAILEIGH AND OTHER SIMILAR TILES

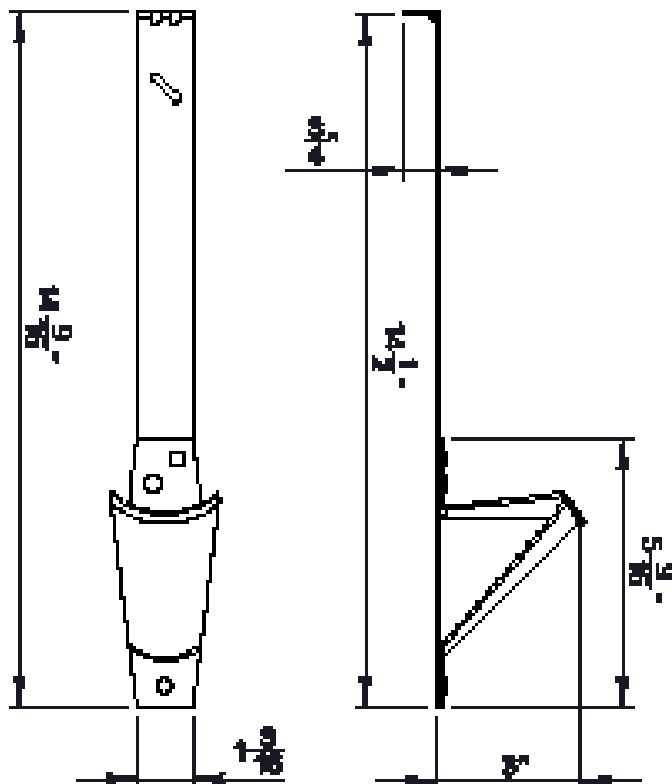

DIMENSIONS
DO NOT SCALE

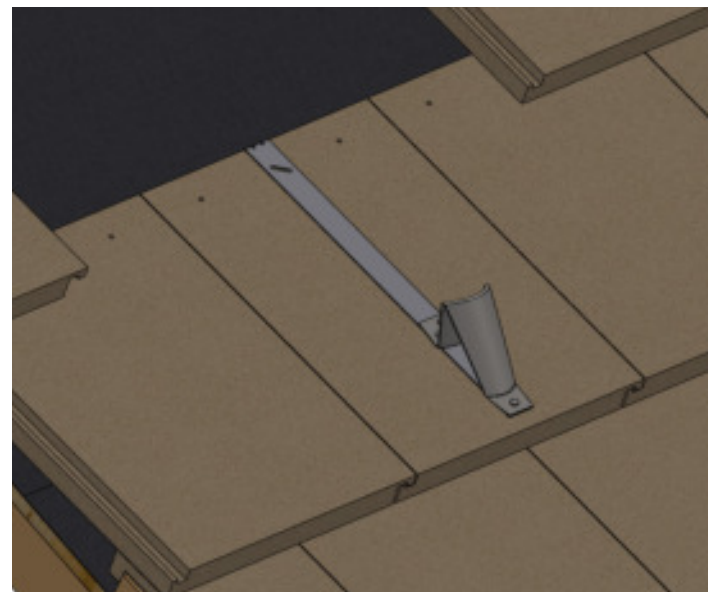

INSTALLATION:
SNOW BRACKET IS INSTALLED WITH (1) 10 D GALVANIZED NAIL ON THE TOP SURFACE OF THE TILE WITH THE TRIANGULAR END OF THE BRACKET OVER THE HEADLAP OF THE TILE.

SNOW RETENTION SYSTEMS