

## TileSeal | Aluminum Tape

### METAL

- Highly durable and weather resistant
- Maximum formability and long term functionality
- Fully recyclable

### CONTINUOUS CORRUGATION

- Stretching factor of 30%
- Conforms to roof surface
- Suitable for hip and ridge application
- Easy installation

### HIGH QUALITY COLOR COATING

- Durable UV resistant

### BUTYL ADHESIVE SHEETS

- Additional security against driving rain and snow

### TECHNICAL INFORMATION

- Body: aluminum, corrugated and colored
- Height Thickness: .0057" with butyl adhesive strips
- Width: 9.5", 11", 13" and 15.75"
- Length: 25 ft./per roll
- Standard Colors: red and black

### WARRANTY

- 25 year limited warranty



**FOR NEW CONSTRUCTION AND RETROFIT**

**USED ON: TILE ROOFS**

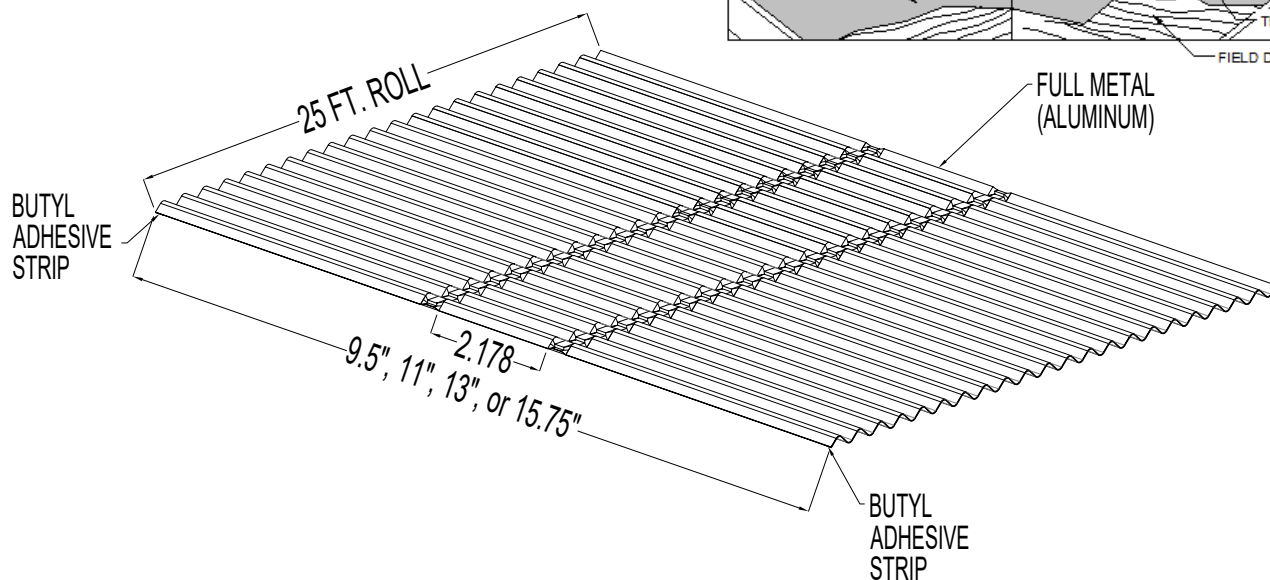
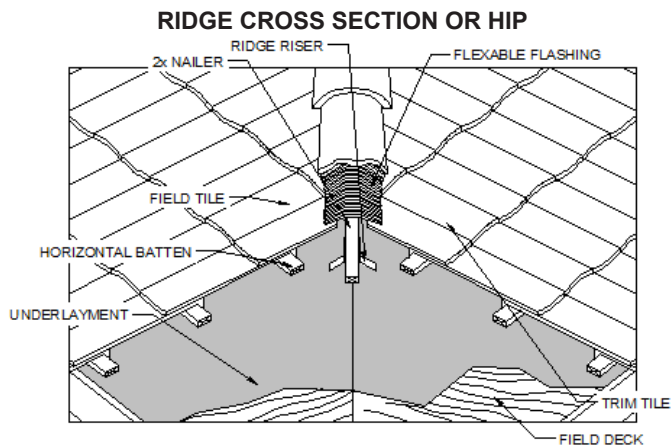

**DIMENSIONS**  
DO NOT SCALE

**VENTILATION AND FLASHING SYSTEMS**



## TileSeal | Aluminum Tape

<b>ALUMINUM TAPE</b>			
STRUCTURE	Aluminum tape .0057" thick with color coating and butyl adhesive strips		
MATERIAL FRONT	Aluminum 99.5 (soft)		
MATERIAL CHARACTERISTICS	Lacquer		
	Quantity (dry)	12 - 15 g/m <sup>2</sup>	
	Standard colors:	Red	(similar RAL 8004)
		Black	(similar RAL 9004)
	Gloss degree:	60%	
	60° W:	35 +/- 5%	ECCAT 2
	Chalking:	< 15% after 1.000 h QUVB	ECCAT 14
	Salt spray test:	no damage after 1.000 h stress	ECCAT 9
	Water dip stability:	minimum loss of gloss after 1.000 h stress	ECCAT 9
	Kesternich-test	no damage after 1.000 h stress	ECCAT 16
	T-bending:	T = 0.5 no cracks	ECCAT 7
QUV-test (UVB 313):	remaining gloss < 5% after 1.000 h stress	ECCAT 3	
<b>ADHESIVE STRIPS</b>			
STRUCTURE	Extruded strip of very tacky sealant/adhesive based on butyl rubber overed with a release film		
MATERIAL BACK SIDE	Butyl, Polyisobutylene		
MATERIAL CHARACTERISTICS (OUTSIDE)	Specific weight:	1.49 g/ml	
	Temperature resistance:	continuously from -50°C - +90°C	
	Plasticity:	70<P>100 acc. NFP 85513	
	Plastic flow:	0 mm by 23° C and 0 mm by 70° C acc norm NFP 85501	
	Drying substance:	100%	
	Shearing stress-resisted:	speed 100 mm/min 0.107 Pa	
	Tearing off resistance:	speed 100 mm/min 0.233 Pa	
	Elongation at break:	> 500%	
	Steam permeability	Impermeable	
	Migration of components:	no migration, no spotting	
	Compatibility with paints:	can be re-painted	
	Resistance:	Water	excellent
		Sea Water	excellent
		House detergent	very good
Acid (diluted)		good	
Base (diluted)		very good	
Alcohol		average	
	Organic solvents	poor	