



D2HH DECK MOUNT

DESCRIPTION

- Designed for most stick framed roof types
- Accepts 1" (1.315"OD) fence tube
- Installed using (4) 3/8" lag bolts or (4) 1/4" SDS screws
- Must be installed into structural roof member such as a truss or rafter beam
- All roof penetrations that go through the underlayment are required to be flashed or sealed
- Ice Flags recommended
- Powder coated to match roofing material color
- Overall dimensions: 12"L X 2"W X 10.50"H

MATERIALS

- Steel: 1/4" (ASTM A36)
- Copper: 1/4" (ASTM B152)
- Weathering Steel (known as CORTEN®): 1/4" (ASTM A588)

COLORS/FINISHES

- Raw steel
- Electro-galvanized steel
- Zinc steel
- Mill finish Copper
- Mill finish A588
- Powder coating available in many colors visit <http://trasnowandsun.com/color-chart/> to see color chart

NOTE: Due to specific job conditions, TRA Snow and Sun will only warranty a snow retention system/layout that has been designed by TRA Snow and Sun.

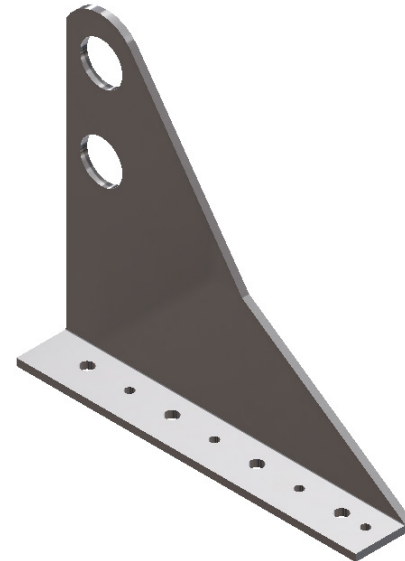
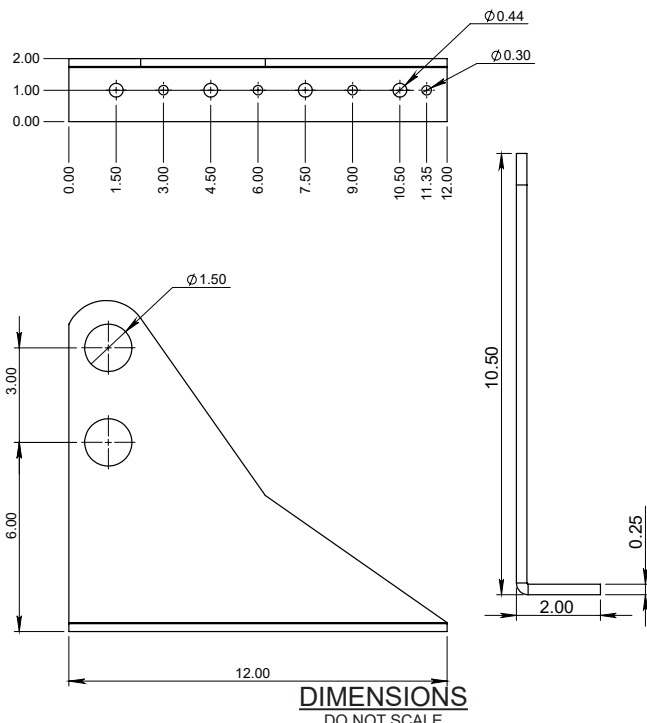

**2 TUBE SNOW FENCE SYSTEM
USED ON: ASPHALT SHINGLES, CEDAR
SHINGLES, FLAT SEAM METAL, GRANULE
METAL, METAL PANEL, SLATE, SIMULATE
SLATE, & WOOD SHAKES**

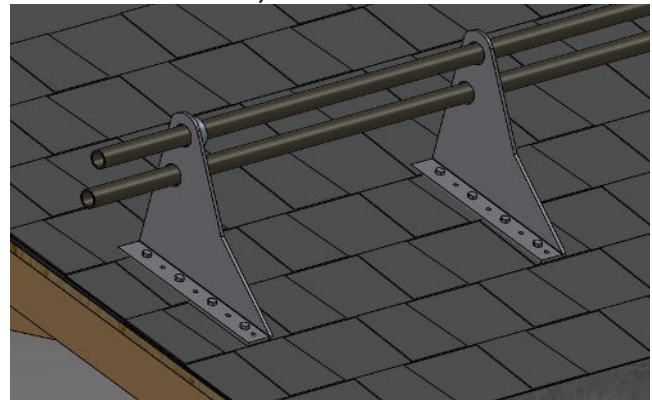

INSTALLATION INSTRUCTIONS:

THE DECK MOUNT IS INSTALLED WITH A MINIMUM OF FOUR 3/8" LAG BOLTS OR FOUR 1/4" SDS SCREWS SCREWED INTO TRUSS, BLOCKING, OR OTHER STRUCTURAL FRAMING (3" MINIMUM DEPTH STRUCTURE EMBED). POSITION SNOW FENCE HOLES DIRECTLY OVER CENTER OF TRUSS. WE ADVISE PLACING SOME TYPE OF CAULKING OR SEALANT IN THE LOCATION OF THE HOLES BEFORE INSTALLING SCREWS. FLASHINGS CAN THEN BE FABRICATED AND PLACED AT THE INSTALLERS DISCRETION. AS AN OPTION, WE DO OFFER BUTYL FLASHING THAT IS APPLIED UNDER THE DECK MOUNT.

* ALL ROOF PENETRATIONS THAT GO THROUGH THE UNDERLAYMENT ARE REQUIRED TO BE FLASHED OR SEALED.

SNOW RETENTION SYSTEMS