

TEKTON®

Model #
24330

TORQUE WRENCH OPERATOR'S MANUAL

STORE THIS MANUAL IN A SAFE
PLACE FOR FUTURE REFERENCE

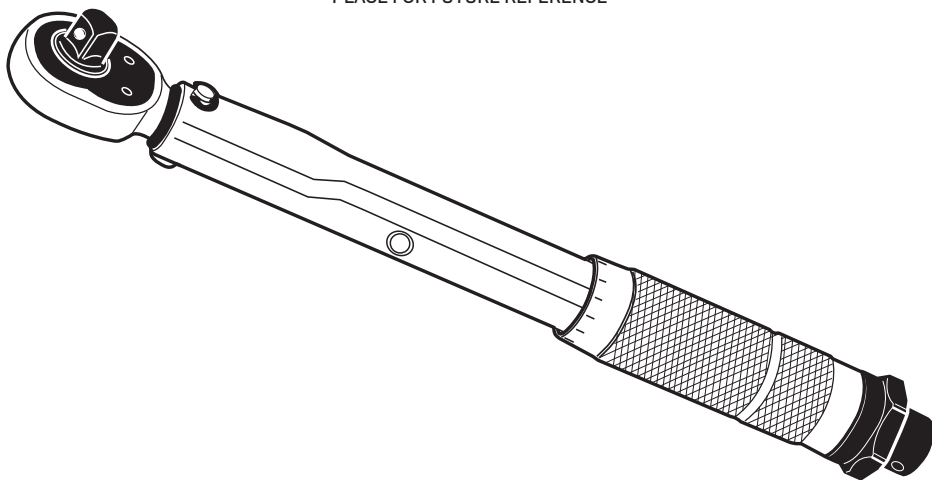

NEED HELP?

888-648-3371
support@tekton.com



Please read and understand entire manual, including all safety information, before using torque wrench. This tool is a precision measuring instrument. Handle with care and store properly. Do not attempt to increase leverage of this wrench with any other device. Failure to follow all instructions could result in damage to torque wrench, property damage, or injury.

- At low torque settings, pull wrench slowly to observe click.
- Wrench is shipped ready to use, calibrated and tested to an accuracy of +/- 4%. To maintain this accuracy, it is important that wrench is stored at lowest torque setting, 10 ft.-lb (13.6 Nm). This setting relieves extra tension on the internal spring, eliminating fatigue that can adversely affect accuracy.

SETTING TORQUE READING

This is a dual-range torque wrench marked with foot pounds (ft.-lb.) and Newton meters (Nm) on opposite sides of handle.

The torque scale is marked on the handle body with more precise subdivisions on the knurled handle (Fig. A). In these instructions the handle body scale will be referred to as the "main scale" and the knurled handle scale will be referred to as the "micrometer scale".

 Tighten/adjust lock nut and knurled handle by hand only.

Foot Pounds (Example reading: 53 ft.-lb.)

1. Locate lock nut on the end of handle. Unlock knurled handle by turning lock nut counterclockwise.
2. **COARSE SCALE ADJUSTMENT (Fig. B):** Using ft.-lb. scale, turn knurled handle until its top edge is even with the horizontal "50" mark on main scale and the "0" mark on micrometer scale is centered on vertical line of main scale.
3. **FINE SCALE ADJUSTMENT (Fig. C):** The micrometer scale divides the main scale markings into 5 divisions. Every micrometer scale marking equals 1 ft.-lb., also known as the minimum increment. To increase torque from 50 to 53, turn micrometer handle clockwise until "3" mark is centered on vertical line of main scale. 50 ft.-lb. (main scale) + 3 ft.-lb. (micrometer scale) = 53 ft.-lb.
4. Lock torque setting by turning lock nut clockwise until snug. Wrench is now set to measure 53 ft.-lb. of torque and ready to use.

Newton Meters (Example reading: 80.0 Nm)

Setting desired torque on the Nm scale uses the same procedure described above for ft.-lb. scale. The micrometer scale divides the main scale markings into 5 divisions. Every micrometer scale marking equals 1.36 Nm, also known as the minimum increment.

To set a torque value of 80.0 Nm, turn knurled micrometer handle until top is aligned with "74.6" mark on main scale and the "0" mark on micrometer scale is centered on vertical line of main scale. To increase torque from 74.6 Nm to 80.0 Nm, turn micrometer handle clockwise until the "4" mark is centered on vertical line of main scale. $80.0 \text{ Nm} - 74.6 \text{ Nm} = 5.4 \text{ Nm}$. $5.4 \text{ Nm} \div 1.36 \approx 4$ micrometer scale markings. Wrench is now set to measure 80.0 Nm of torque and ready to use.

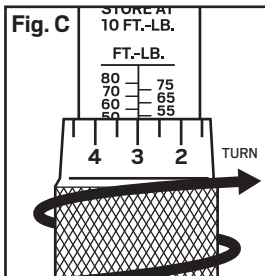
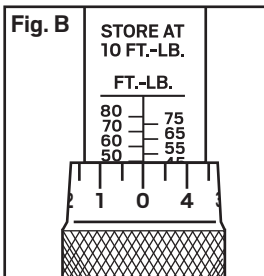
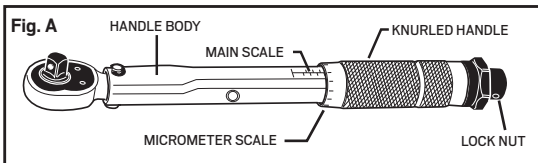

WRENCH OPERATION

Fig. D illustrates the basic operation of the torque wrench. For accurate operation, grasp the knurled handle only and apply pulling force. When the desired torque setting is reached, the roller bearing and roller pin will roll over each other, causing a click you can hear and feel. NOTE: At low torque settings, click can be subtle. Use wrench in a quiet environment.

1. Install proper socket/attachment to square drive. Place socket on nut/bolt to be tightened.
2. Operate torque wrench the same as a standard socket wrench to tighten nut/bolt. As nut/bolt becomes snug, slow operation to a smooth, steady pull. Operating wrench too quickly or with too much force may cause you to miss the exact torque setting. At the instant the wrench clicks, torque setting has been reached. Stop pulling wrench and release pressure on handle. Do not continue to pull after torque setting is reached. Doing so will overtighten the nut/bolt and could damage wrench. Once pressure is released from the handle, wrench will automatically reset for next operation. NOTE: At low torque settings, use extra care to release wrench at the proper point after it clicks.
3. Wrench does not measure torque below 10 ft.-lb. (13.6 Nm).
4. Do not use wrench to break free stuck fasteners.

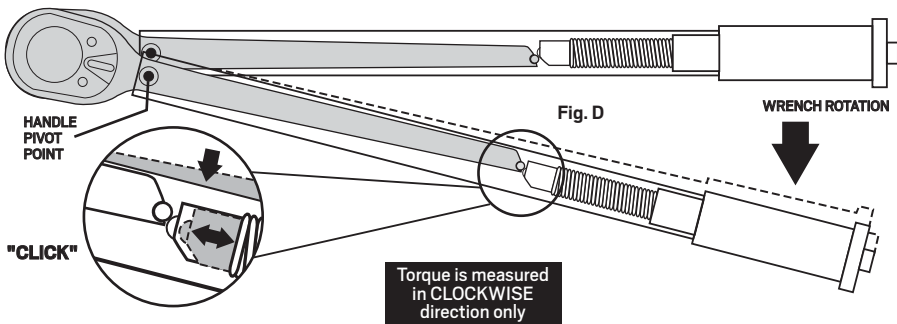

MAINTENANCE AND STORAGE

1. If wrench has not been used for a long period of time, operate it several times at a low torque setting. This will allow internal lubricant to recoat moving parts.
2. When wrench is not in use, keep adjustment at lowest torque setting, 10 ft.-lb. (13.6 Nm) (Fig. E). Do not turn handle below lowest torque setting.
3. This wrench is a precision measuring instrument. Take care to operate wrench correctly. Store in a clean, dry environment.
4. Clean wrench by wiping with a clean, dry, lint-free cloth. Do not immerse in any type of liquid or cleaner. This may damage the internal components of the wrench.

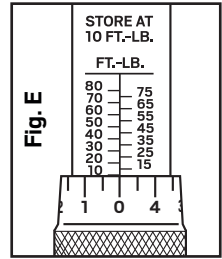

TORQUE UNIT CONVERSION TABLE

FOOT POUNDS (ft.-lb.)	INCH POUNDS (in.-lb.)	NEWTON METERS (Nm)	NEWTON METERS (Nm)	FOOT POUNDS (ft.-lb.)	INCH POUNDS (in.-lb.)	INCH POUNDS (in.-lb.)	FOOT POUNDS (ft.-lb.)	NEWTON METERS (Nm)
5	60	6.78	10	0.83	88.51	100	8.34	11.29
10	120	13.55	20	1.67	177.01	125	10.41	14.12
15	180	20.33	30	2.50	265.52	150	12.50	16.94
20	240	27.11	40	3.33	354.03	175	14.58	19.77
25	300	33.89	50	36.87	442.53	200	16.67	22.59
30	360	40.67	60	44.25	531.04	225	18.75	25.42
35	420	47.45	70	51.63	619.55	250	20.83	28.24
40	480	54.23	80	59.00	708.06	275	22.91	31.07
45	540	61.01	90	66.38	796.56	300	25.00	33.89
50	600	67.79	100	73.75	885.07	325	27.08	36.72
55	660	74.56	110	81.13	973.58	350	29.17	39.54
60	720	81.34	120	88.50	1062.09	375	31.25	42.37
65	780	88.12	130	95.88	1150.59	400	33.33	45.19
70	840	94.90	140	103.25	1236.10	425	35.41	48.01
75	900	101.68	150	110.63	1327.61	450	37.50	50.84
80	960	108.46	160	118.01	1416.12	475	39.58	53.66
85	1020	115.24	170	125.38	1504.62	500	41.67	56.49
90	1080	122.02	180	132.76	1593.13	525	43.75	59.31
95	1140	128.80	190	140.13	1681.64	550	45.83	62.14
100	1200	135.58	200	147.51	1770.15	575	47.91	64.96
105	1260	142.36	210	154.88	1858.65	600	50.00	67.79
110	1320	149.13	220	162.26	1947.16	625	52.08	70.61
115	1380	155.91	230	169.64	2035.67	650	54.16	73.44
120	1440	162.69	240	177.01	2124.17	675	56.25	76.26
125	1500	169.47	250	184.39	2212.68	700	58.33	79.09
						725	60.41	81.91
						750	62.50	84.73
						775	64.58	87.56
						800	66.67	90.38
						825	68.75	93.21
						850	70.83	96.03
						875	72.91	98.86
						900	75.00	101.68
						925	77.08	104.51
						950	79.16	107.33
						975	81.25	110.16

CONVERSIONS		
1 ft.-lb. =	1 in.-lb. =	1 Nm =
0.138 m-kg	0.0833 ft.-lb.	0.737 ft.-lb.
12.0 in.-lb.	0.113 Nm	8.85 in.-lb.
1.35 Nm	0.0115 m-kg	0.102 m-kg
13.8 cm-kg	1.15 cm-kg	10.2 cm-kg

NOTE: Exploded view diagram provided for illustration purposes only. Do not disassemble any part of torque wrench. There are no user serviceable parts on or inside wrench. Parts shown and assembly may differ slightly based on model.

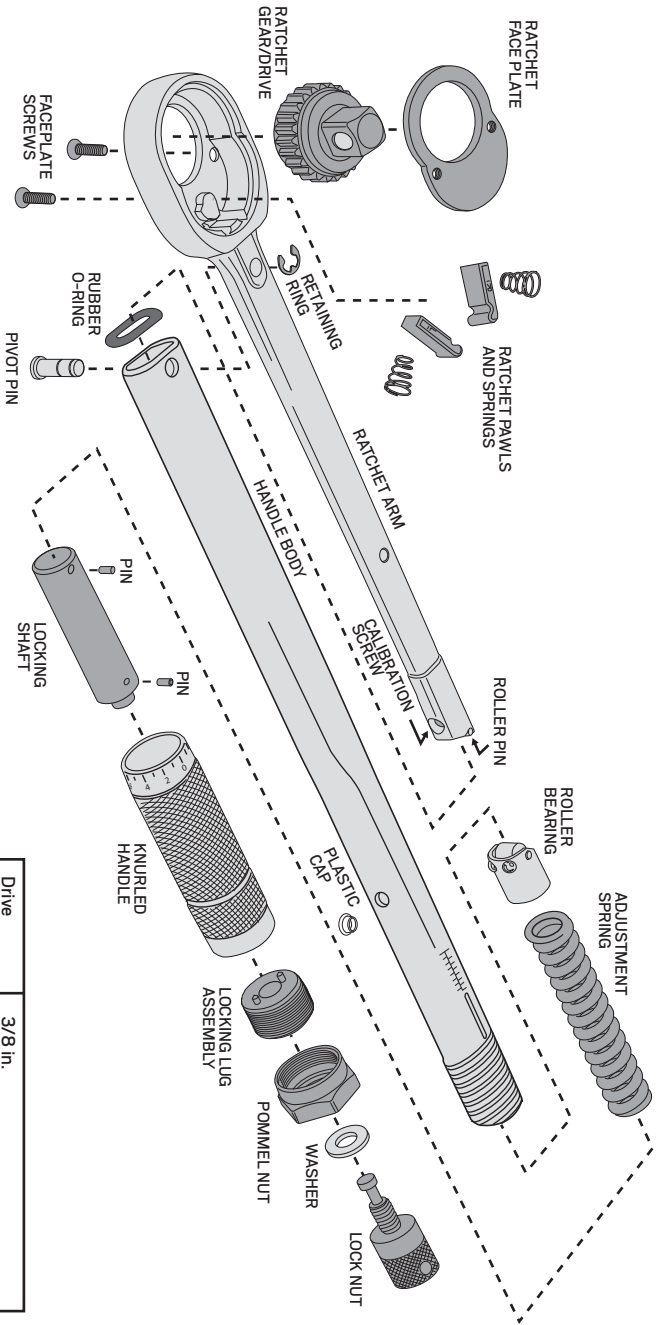

TEKTON®
 3707 Roger B Chaffee SE
 Grand Rapids, MI 49548
 Made in Taiwan

© 2017
TEKTON.COM

Drive	3/8 in.
Ratchet	24 Tooth
Length	15.5 in.
Dual Range	10 - 80 ft.-lb. and 13.6 - 108.5 Nm
Increment	1 ft.-lb. (1.36 Nm)
Accuracy	+/- 4%