

ICC#: ESR-1787
TileVent | Copper Tape

METAL

- Highly durable and weather resistant
- Maximum formability and long term functionality
- Fully recyclable

ICC# ESR-1787

- Passed Dade County wind driven rain test (PA100(A)-95)
- Passed ICC dust test (AC132)

NET FREE AIRFLOW

- 10.3 in² per running foot (9.5", 11", 13" and 15.75" width)

SOLID COPPER

- Prevents moss and organic build-up on roof surface

CONTINUOUS CORRUGATION

- Stretching factor of 30%
- Conforms to roof surface
- Application for hip and ridge
- Easy installation

PERFORATED

- Continuous air exhaust
- Reliable weather block

BUTYL ADHESIVE SHEETS

- Additional security against driving rain and snow

TECHNICAL INFORMATION

- Body: corrugated copper
- Height Thickness: .003" with butyl adhesive strips
- Width: 9.5", 11", 13" and 15.75"
- Length: 25 ft./per roll
- Standard Colors: mill finish copper

WARRANTY

- 25 year limited warranty



FOR NEW CONSTRUCTION AND RETROFIT

USED ON: TILE ROOFS

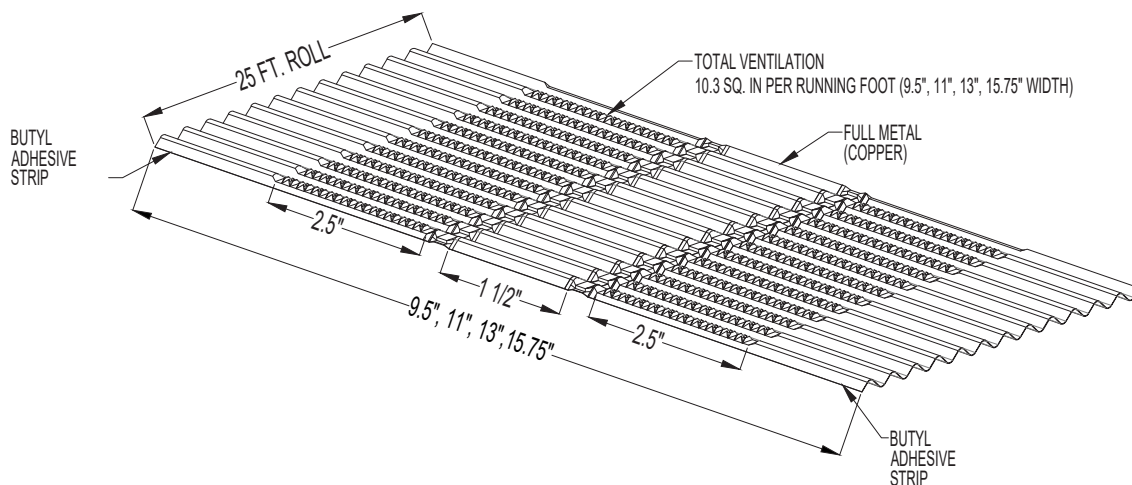
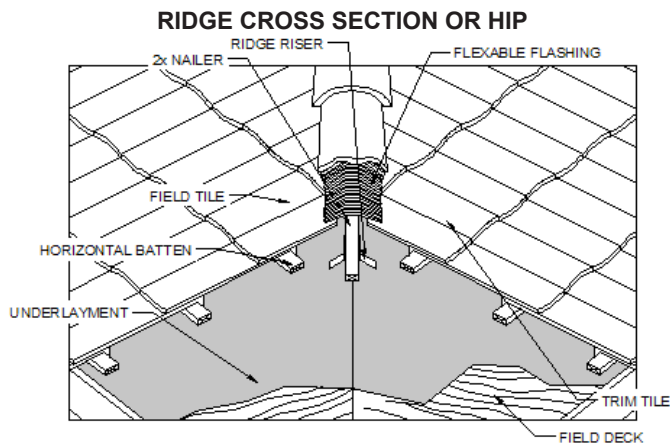

DIMENSIONS
DO NOT SCALE



ICC#: ESR-1787
TileVent | Copper Tape

COPPER TAPE				
STRUCTURE	Copper tape .003" thick with butyl adhesive strips			
MATERIAL FRONT	Copper 99.9 (semihard)			
MATERIAL CHARACTERISTICS	abbreviation	SF-CU/F20	by DIN 77670	
		99.9% Cu	0.01% - 0.04% Phosphorus	
		Thickness	0.08 mm	
		Tensile strength R_m	200 - 250 N/m ²	
		0.2% Elongation limit $R_{p0.2}$	max. 100 N/mm ²	
		Elongation at rupture A_5 :	min. 42%	
		A_{10}	min. 36%	
ADHESIVE STRIPS				
STRUCTURE	Extruded strip of very tacky sealant/adhesive based on butyl rubber covered with a release film			
MATERIAL BACK SIDE	Butyl, Polyisobutylene			
MATERIAL CHARACTERISTICS (OUTSIDE)	Specific weight:	1.49 g/ml		
	Temperature resistance:	-50°C - +90°C		
	Plasticity:	70<P>100 acc. NFP 85513 norm		
	Plastic flow:	0 mm at 23° and 0 mm at 70° acc. NFP 85501 norm		
	Drying substance	100%		
	Shearing stress-resisted:	speed 100 mm/min	0.107 Pa	
	Tearing off resistance:	speed 100 mm/min	0.233 Pa	
	Steam permeability:	> 500%		
	Migration of components:	impermeable		
	Compatibility with paints:	no migration, no spotting		
	Resistance:	Water	excellent	
		Sea water	excellent	
		House detergent	very good	
Weak acid		good		
Basen thinly		very good		
Alcohol		moderately		
	Organic solvents	poor		