



SNOW DIAMOND CLAMP-ON -1 RAIL

DESCRIPTION

- Designed for standing seam metal roofs
- Available for rib types including: Double Lock, Single Lock, Snap Lock, Skyline, etc
- Designed for clamp-on square tubes (see square clamp-on tube product data sheet)
- Allows for full installation without penetration of the roof surface
- Powder coated to match roofing material color
- Overall dimensions: 2.67" L X VAR"W X VAR"H
- Height (HT) of clamp varies based on rib type and height
- Carriage bolt (2) 3/8" Dia X 1-3/4" or 2"

MATERIALS

- Zinc Coated Steel: 3/16" (ASTM A36)
- Stainless Steel: .165" (ASTM A666-03)

COLORS/FINISHES

- Zinc Plated Steel
- Hot-Dipped Galvanized Steel
- Mill Finish Stainless Steel
- Powder coating available in many colors visit <http://trasnowandsun.com/color-chart/> to see color chart

NOTE: Due to specific job conditions, TRA Snow and Sun will only warranty a snow retention system/layout that has been designed by TRA Snow and Sun.

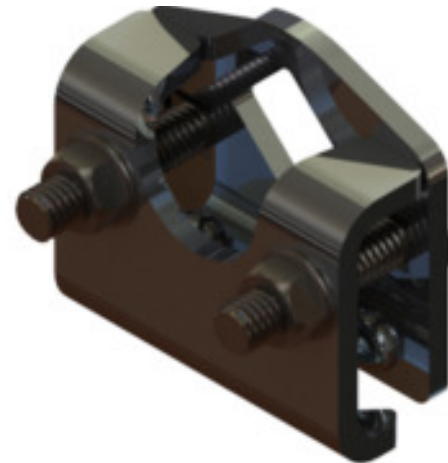

1 RAIL CLAMP-ON SNOW FENCE SYSTEM

USED ON: STANDING SEAM METAL

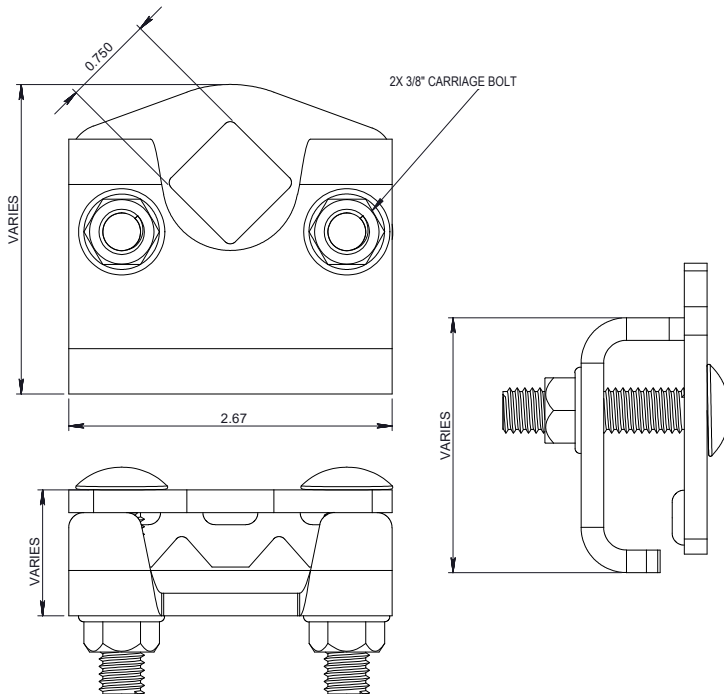
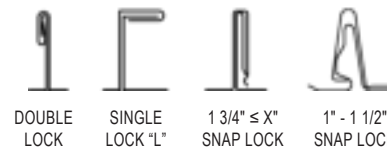

* These dimensions vary based on the panel rib type and height.

DIMENSIONS
DO NOT SCALE

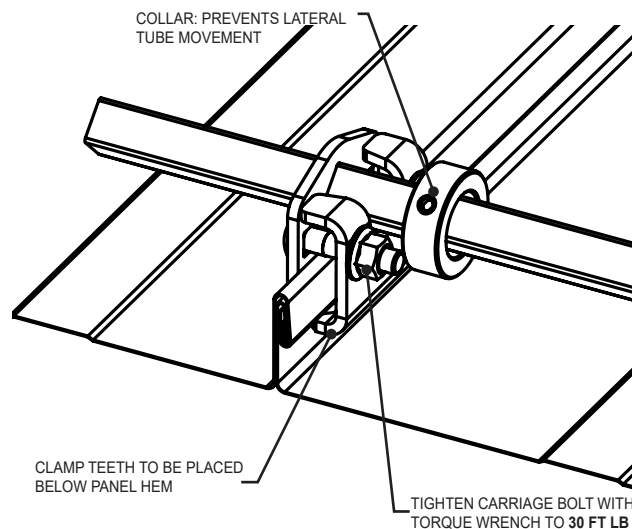

INSTALLATION:

CLAMP THE SNOW FENCE TO THE RIB BY USING A TORQUE WRENCH WITH 30 FT - LBS. OF PRESSURE APPLIED TO EACH BOLT. FOR SPECIFIC ENGINEERING & PLACEMENT CALL TRA SNOW & SUN AT 801-756-8666.

SNOW RETENTION SYSTEMS