



SNOW BRACKET™ SLATE HOOK - APEX

DESCRIPTION

- Designed for use with slate roofs
- No fasteners required
- Powder coated to match roofing material color
- Overall dimensions: 18 11/16" L X 1 3/16" W X 3" H
- Can be powder coated to match roofing material color
- Because of it's unique installation is not warranted and is installed at the contractor's risk.

MATERIALS

- Zinc Coated Steel: 16 ga (ASTM A653)
- Copper: 48 oz (ASTM B152)
- Stainless Steel: 16 ga (ASTM A240)

COLORS/FINISHES

- Zinc Plated
- Powder coating available in many colors visit <http://trasnowandsun.com/color-chart/> to see color chart

NOTE: Due to specific job conditions, TRA Snow and Sun will only warranty a snow retention system/layout that has been designed by TRA Snow and Sun.



FOR RETROFIT APPLICATIONS

USED ON: SLATE ROOFS

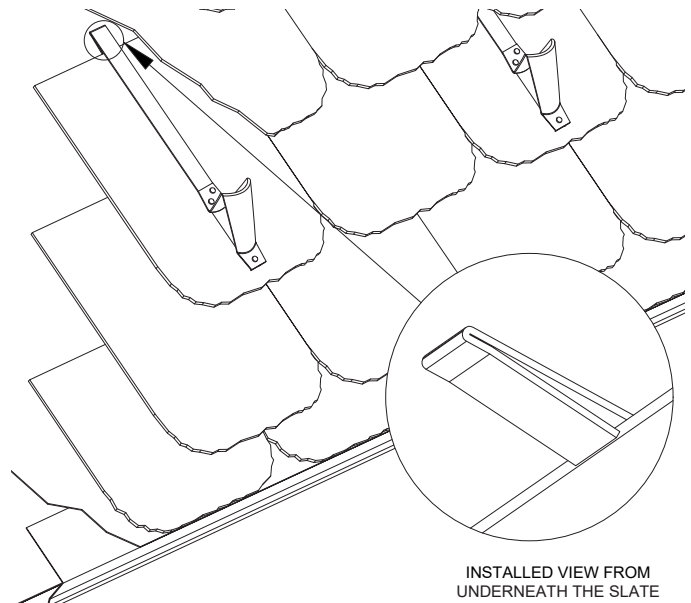
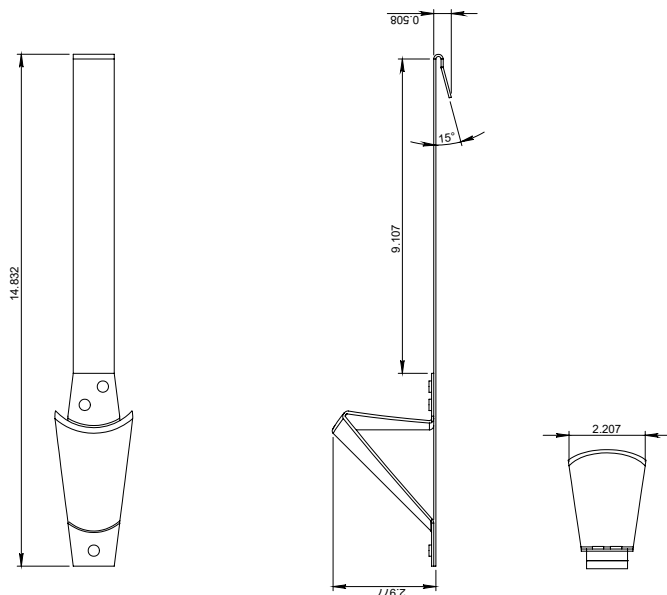

Slide bracket between slate courses and ensure that the bracket hooks on back end of slate. Also, adhere the exposed portion of the bracket using SureBond SB-190. Follow SureBond adhesive instructions.

DIMENSIONS
DO NOT SCALE