



SNOW BRACKET™ C - MUSHROOM

DESCRIPTION

- Designed for new construction or retrofit applications
- Used on 7/8" Corrugated Metal Panels
- Bracket fastens to roof sheathing
- Installed using (2) #14 fasteners
- Can be powder coated to match roofing material color
- Overall dimensions: 4 7/16" L X 1 1/4" W X 3" H
- Weight: 1.2 lbs. each

MATERIALS

- Zinc Coated Steel: 1/4" (ASTM A36)
- Copper: 1/4" (ASTM B152)
- Weathering Steel (known as CORTEN®): 1/4" (ASTM A588)

COLORS/FINISHES

- Zinc Plated
- Powder coating available in many colors visit <http://trasnowandsun.com/color-chart/> to see color chart

NOTE: Due to specific job conditions, TRA Snow and Sun will only warranty a snow retention system/layout that has been designed by TRA Snow and Sun.



FOR NEW CONSTRUCTION OR RETROFIT

USED ON: CORRUGATED METAL PANEL

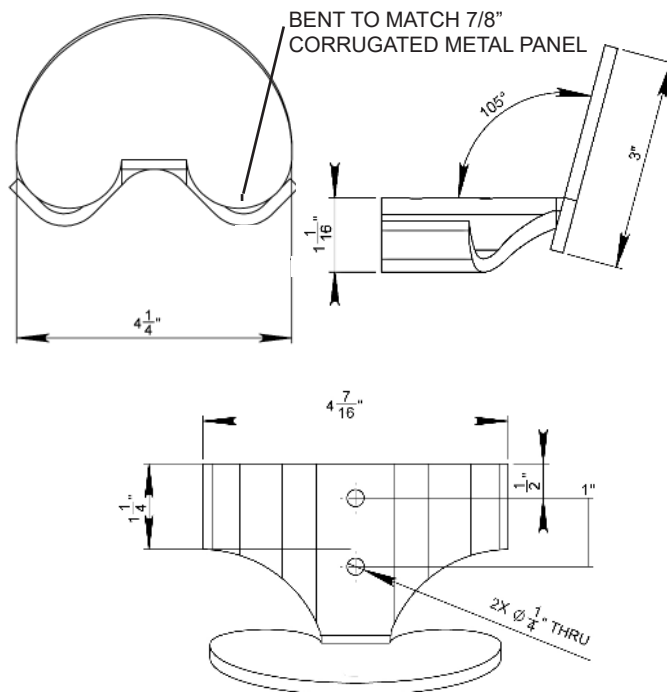

DIMENSIONS
DO NOT SCALE

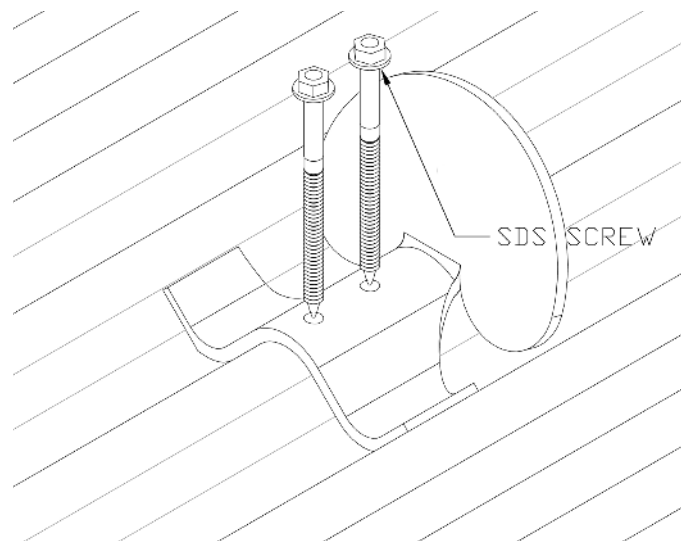

INSTALLATION:

Face the mushroom portion of bracket towards the roof eave (see image above). Install brackets with optional butyl using (2) #14 screws fastened through roof material and sheathing below. All roof penetrations that go through the underlayment are required to be flashed or sealed.

SNOW RETENTION SYSTEMS