



SNOW BRACKET™ B - CLASSIC

DESCRIPTION

- Designed for use with concrete tiles 15" in length which are installed using horizontal battens
- No fasteners required
- Can be powder coated to match roofing material color
- Overall dimensions: 16-13/16"L X 1-3/16"W X 4-5/8" H

MATERIALS

- Zinc Coated Steel: 16 ga (ASTM A653)
- Copper: 48 oz (ASTM B152)
- Stainless Steel: 16 ga (ASTM A240)

COLORS/FINISHES

- Zinc Plated
- Powder coating available in many colors visit <http://trasnowandsun.com/color-chart/> to see color chart

NOTE: Due to specific job conditions, TRA Snow and Sun will only warranty a snow retention system/layout that has been designed by TRA Snow and Sun.



FOR NEW CONSTRUCTION OR RETROFIT

USED ON: BARTILE, VANDEHEY AND OTHER SIMILAR TILES

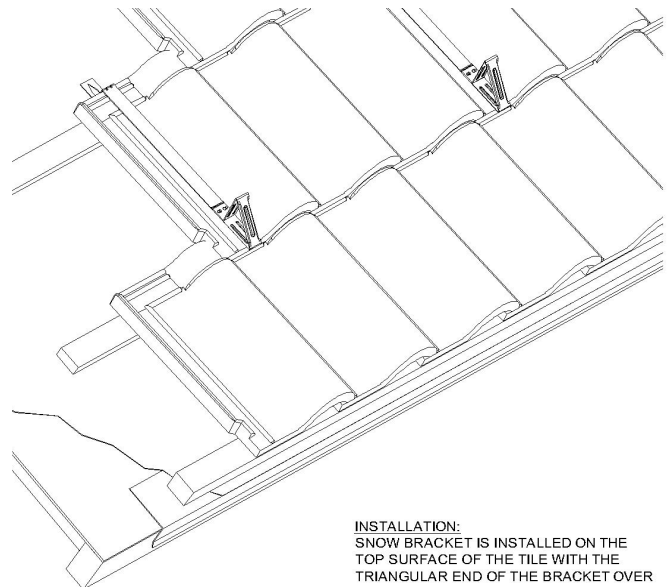

**SNOW BRACKET 'B'
S TILE ROOF**

INSTALLATION:
SNOW BRACKET IS INSTALLED ON THE TOP SURFACE OF THE TILE WITH THE TRIANGULAR END OF THE BRACKET OVER THE HEADLAP OF THE TILE AND THE SPIKE INSTALLED INTO 1 X 2 BATTEN.

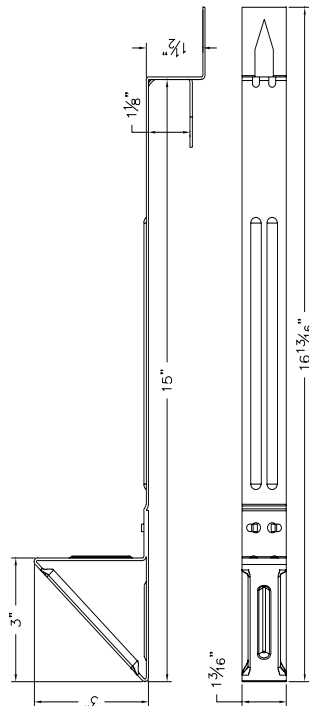

DIMENSIONS
DO NOT SCALE