



SNOW BLOCKER 1 RAIL

DESCRIPTION

- Designed for use with exposed fastener metal panel roofing
- Fastens to rafter, purlin, or roof sheathing
- Superior strength
- Can be powder coated to match roofing material color
- Overall dimensions: 4 1/2" L X 1 5/8" W X 3" H

MATERIALS

- Steel :: 3/16" (ASTM A1011 & ASTM A880)
- Copper :: 3/8" (ASTM B152)
- Cor-Ten® :: 3/16" (ASTM A588)

COLORS/FINISHES

- Raw steel
- Electro-galvanized steel
- Hot-dipped galvanized steel
- Mill finish Copper
- Mill finish Cor-Ten®
- Powder coating available in many colors visit <http://trasnowandsun.com/color-chart/> to see color chart

NOTE: Due to specific job conditions, TRA Snow and Sun will only warranty a snow retention system/layout that has been designed by TRA Snow and Sun.

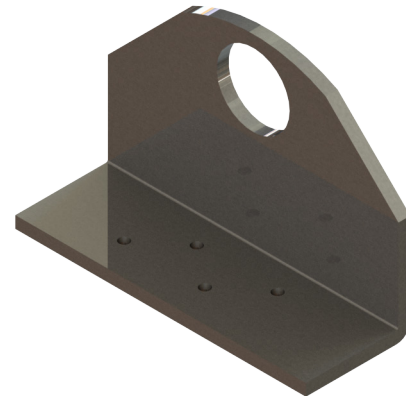

FOR NEW CONSTRUCTION OR RETROFIT

USED ON: EXPOSED FASTENER METAL PANEL

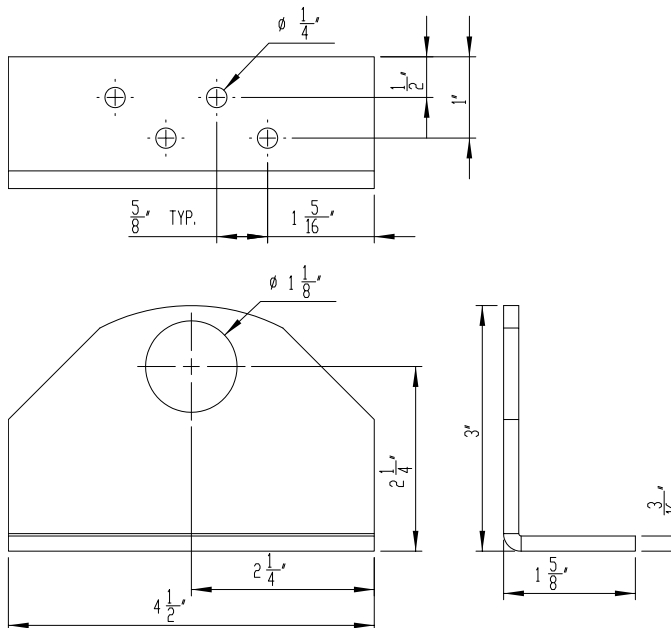

DIMENSIONS

DO NOT SCALE

*Dimensions shown are in inches.

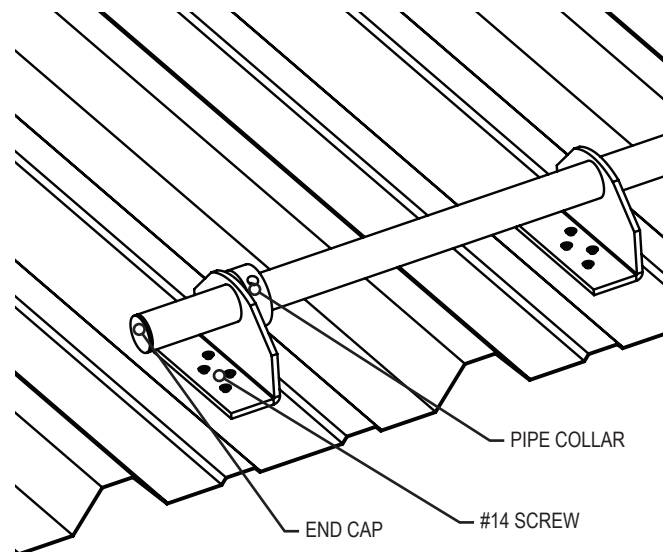

Snow Fence Bracket to be installed using (4) #14 fasteners secured to the purlins or roof sheathing. Space Snow Fence Brackets horizontally according to TRA Snow and Sun recommendations. Collars should be installed inside the last bracket and End Caps should be placed at pipe terminations.

INSTALLATION

DO NOT SCALE

SNOW RETENTION SYSTEMS